

WEAPONMOUNT 16

Small size, low weight weapon mount for FN MAG / FN MINIMI



PRODUCT FEATURES

- The Multifunctional Adapter fits all variants of the FN MAG and FN MINIMI.
- Mounting interface with G3-taper

TECHNICAL SPECIFIKATION

Elevation angle 35°/-20°

Stepless adjustable dump stop 0-20°

Weight: 1,5kg

Material:

Titanium G3 taper

Steel frame

Aluminum dump stop

OPTIONS

Interface to various sector limiters

Storage bag Link and cartridge collector 16 (MFC 16)



GRAPHICS



WITH FN / MAG (7,62MM)

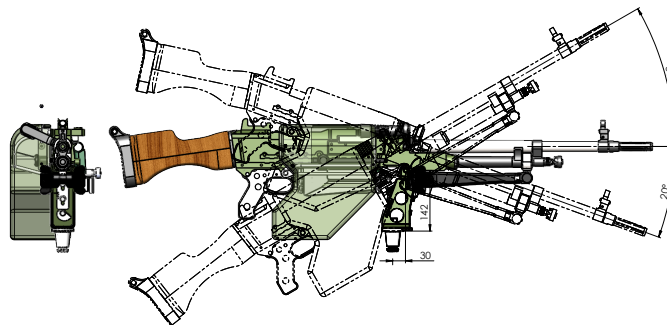

WITH FN / MINIMI (5,56MM)

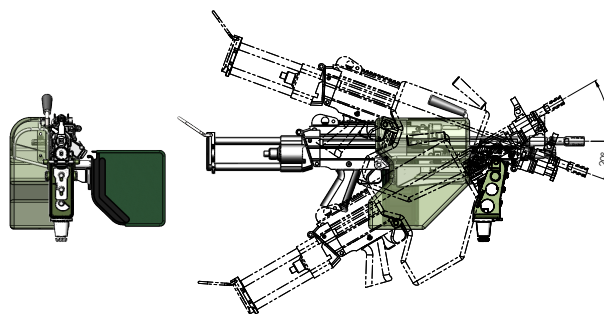

DIMENSIONS

